



POWER VENTER SYSTEM

Model: PVU-300



Included is one ETL LISTED power venter to be used for side wall venting of a single 120/24 VAC controlled furnace, boiler, or water heater which burns natural or LP gas, or oil. The PVU may also be used to vent a single 24 VAC controlled gas fired furnace or boiler and a 30 millivolt residential gas fired water heater.

TYPICAL VENTING SYSTEM COMPONENTS

ETL LISTED PVU-300 POWER VENTER with pre-wired integral Universal Control (24VAC and 120 VAC), factory set Draft Proving Switch, and direct access Terminal Blocks.

- Side Wall Vent Hood (Not included)
- Barometric Draft Control (Not Included)
- Spill Switches (Not included)

CONTENTS	PAGE
System Operation	2
Power Venter Sizing	2-3
Installation Safety Instructions	3-4
Installation of Power Venter	4-6
General Wiring Instructions	6
PVU Internal Wiring Schematic	6-8
Adjusting Thermostat Anticipator	8
Airflow Adjustments	9
General Installation Inspection	9
System Control Check Procedures	10
Troubleshooting Tips	10
Maintenance	10
Replacement Parts List	10
Multiple Venting Systems	11-13
Venting System Operational Information	15
Installation Information	15

This device MUST be installed by a qualified agency in accordance with the manufacturers installation instructions.

The definition of a qualified agency is: *any individual, firm, corporation or company which either in person or through a representative is engaged in, and is responsible for, the installation and operation of gas appliances, who is experienced in such work, familiar with all the precautions required, and has complied with the requirements of the authority having jurisdiction.*

DO NOT DESTROY

THESE INSTRUCTIONS MUST REMAIN WITH EQUIPMENT



FIELD CONTROLS

The Venting Solutions Company™

2630 Airport Road · Kinston, NC 28504
Phone: 252-522-3031 · Fax: 252-522-0214
www.fieldcontrols.com

UNIT SPECIFICATIONS (See Table 1 and Figure 1)

Table 1

UNIT DIMENSIONS (INCHES)				
MODEL	"H"	"W"	"D"	I/O*
PVU-300	7.5	11.5	7.0	4/4

*Inlet and outlet diameter.

ELECTRICAL RATINGS						
MODEL	VAC	Hz	RPM	WATT	AMP	TP**
PVU-300	115	60	3000	145	2.1	YES

**Thermally protected motor.

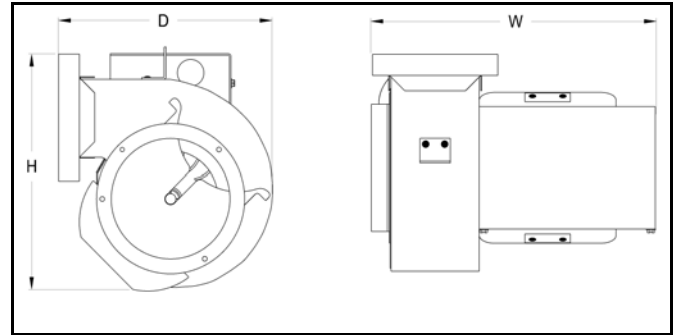

Figure 1

SIDEWALL VENT HOODS (Model SWH-1)

Sidewall vent hoods are available in the following sizes. The vent hood should be chosen that matches the outlet size of the Power Venter. (See Figure 2) **NOTE:** When using different sizes consider reducers and specific size pipe when determining equivalent length of vent pipe.

- SWH-1-3 - 3 inch
- SWH-1-4 - 4 inch
- SWH-1-5 - 5 inch
- SWH-1-6 - 6 inch
- SWH-1-8 - 8 inch

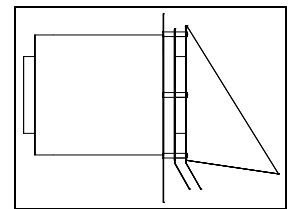

Figure 2

SYSTEM OPERATION

1. The thermostat (wall thermostat, or aquastat) calls for heat and energizes a relay, which activates the power venter. After the venter motor has come up to speed, the pressure switch closes. This completes the circuit to the burner and allows the burner to fire.
2. For millivolt controlled water heaters, the gas pressure switch on the gas valve activates the power venter at the same time as the burner fires.
3. After the heating requirement has been satisfied, the thermostat circuit will open and de-activate the burner and power venter circuit.
4. The post purge timer continues to run the power venter for a period of time after the burner has shut off to purge remaining flue gases.

POWER VENTER SIZING

In order to choose the correct size power venter for a particular installation, the total input firing rate and total equivalent length of vent pipe to be used must be known. Refer to Table 2 to determine the maximum allowable equivalent feet of pipe for each model used with the pipe diameters shown. When venting multiple appliances, add the input of each appliance to determine the total input. Always choose a power venter that is capable of handling more than the system requires. The choke plate can be adjusted to compensate for the difference.

Table 2

MAXIMUM EQUIVALENT HORIZONTAL PIPE LENGTH (FEET)			
BTU/HR INPUT	VENTER MODEL NO. AND VENT PIPE DIAMETER		
	PVU-300		
	4"	5"	6"
100,000	305	---	---
145,000	145	247	334
220,000	64	100	147
310,000	---	54	74

PROCEDURE FOR CALCULATING TOTAL EQUIVALENT PIPE LENGTH IN FEET

1. Calculate the total equivalent feet for each type of fitting used in the venting system from the following chart.
2. Calculate the total amount of feet for the straight lengths of vent pipe.
3. Add the equivalent feet for the fittings with the total amount of feet of straight lengths.

Table 3

EQUIVALENT LENGTH (FEET) OF VENT PIPE FOR VENT PIPE FITTINGS									
VENT PIPE FITTINGS	VENT PIPE DIAMETER								
	3"	4"	5"	6"	7"	8"	9"	10"	
TEE	19	25	31	38	44	50	56	63	
90° ELBOW	5	7	9	11	12	14	16	18	
45° ELBOW	3	4	4	5	6	7	8	9	
REDUCER (d/D)*	1/4	8	11	14	17	19	22	25	28
	1/2	5	7	8	10	12	13	15	17
	3/4	2	3	3	4	4	5	6	6

*Reducer or increaser ratio (d/D) small diameter divided by the larger diameter. (See Figure 3)

Example: 4" to 8" reducer, the reducer ratio is $d/D = 4/8 = 1/2$. To estimate the equivalent foot length for the fitting, use the smaller pipe diameter for the equivalent length figure. **Example:** 4" to 8" reducer; the reducer ratio is 1/2 and the smaller pipe diameter is 4". So, from the chart, the equivalent feet would be 7 feet.

Example: System Pipe Size = 4"

- Step 1 2 – 90° Elbows (4") = 14 Ft.
- Step 2 10 - 2 Ft. Lengths of 4" Pipe = 20 Ft.
- Step 3 Total Equivalent Feet = 14 Ft. + 20 Ft. = 34 Ft.

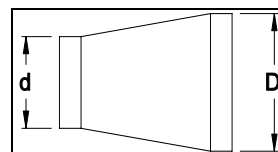

Figure 3

INSTALLATION SAFETY INSTRUCTIONS

CAUTION: This device must be installed by a qualified installer in accordance with the manufacturer's installation instructions. Appliances should have a minimum of 75% combustion efficiency or have a maximum measured flue gas temperature of 550°F at the inlet of the venter.

1. The power venting system must be installed by a qualified installer. "Qualified Installer" shall mean an individual who has been properly trained or a licensed installer. The installer must write or imprint his name, phone number and date of installation on the installation tag. The tag should be attached to the power venter unit. Recording burner and venting system initial operational information is recommended as a guide for service or burner tune-up. Enter this on the back page of this manual.
2. Safety inspection of a venting system should be performed before and after installing a power venting system on an existing or new appliance. Procedures to follow are those recommended by the National Fuel Gas Code, A.N.S.I.Z223.1 or refer to the "General Installation Inspection" section of this manual.
3. Plan the vent system layout before installation to avoid the possibility of accidental contact with concealed wiring or plumbing inside walls.
4. Single wall vent pipe may be used to join an appliance to the venting system, but if proper clearances cannot be maintained from combustible materials, Class B Vent Pipe should be used for gas appliances. Refer to national or local codes for guidelines. Also, a minimum of 6 inches clearance between the venter housing and combustible materials must be maintained.
5. Disconnect power supply before making wiring connections to prevent electrical shock and equipment damage.
6. This equipment is designed to overcome minor negative pressure conditions. To ensure extreme negative pressure does not exist, follow the "General Installation Inspection" section of this manual.
7. Heating appliances equipped with draft hoods, such as boilers or furnaces, LP and natural gas appliances SHOULD have a secondary spillage switch installed. On appliances without draft hoods, it is recommended that the secondary safety switch GSK-3 be installed into the system. Gas-fired 30 millivolt power systems MUST be equipped with a spillage switch.

8. Air flow adjustment **MUST** be made to ensure appliance efficiency. This should be done at the appliance exhaust outlet with a velocity meter, draft gauge or by the "match test procedure". The match test is in accordance with National Fuel Gas Code A.N.S.I.Z223.1, Section 8.6.
9. On heating appliances not equipped with a draft hood, a barometric draft control **MUST** be installed to regulate proper air flow and fluctuations in the system's air flow during operation. Fluctuations can come from wind loads on the outlet of the venter, house depressurization during windy days and the different house ventilation requirements between summer and winter operation. Use a Field Controls Type MG-1 Barometric Draft Control. Gas-fired draft induced systems should have a single-acting or double-acting barometric draft control installed.

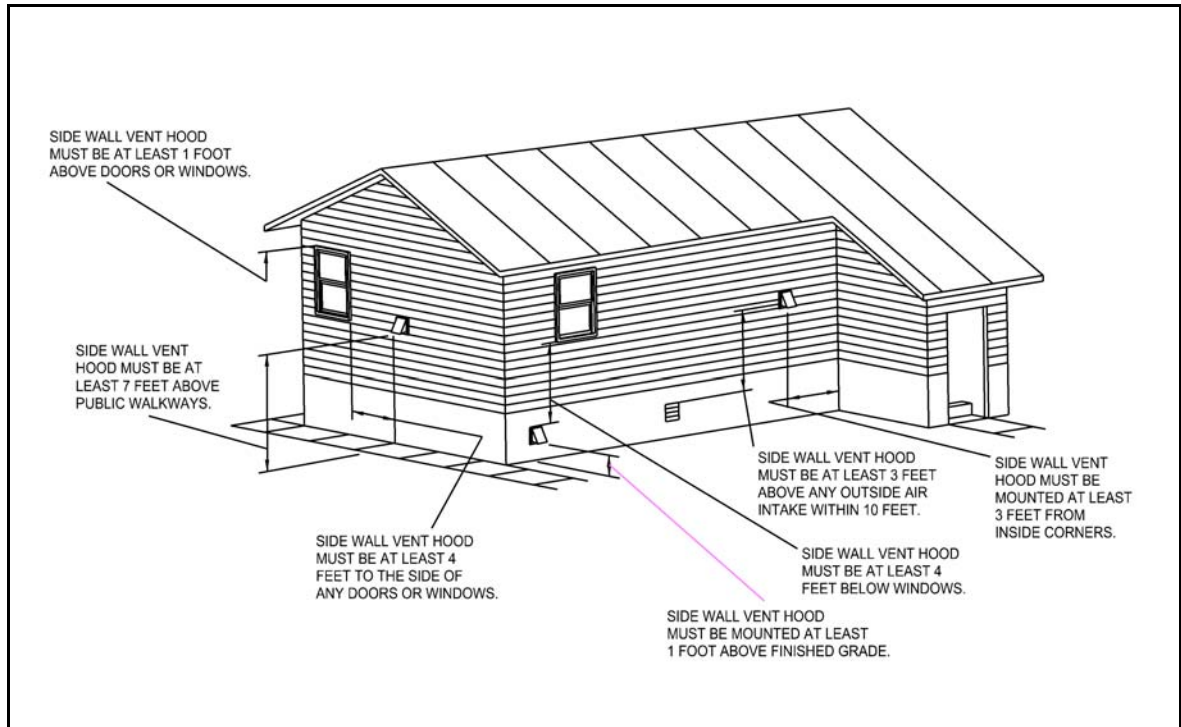

Diagram A

INSTALLATION OF POWER VENTER

CAUTION: Failure to install, maintain and/or operate the power venting system in accordance with manufacturer's instructions will result in conditions which may produce bodily injury and/or property damage.

1. Remove power venter from box and inspect unit for damage. If the carton has been crushed or mutilated, check unit very carefully for damage. Rotate venter wheel to insure that the motor and venter wheel rotate freely. **DO NOT** install if any damage is apparent. Refer to unit sizing chart to check proper venting sizing.
2. Location of the termination of the venting system should be installed in accordance with the National Fuel Gas Code, A.N.S.I.Z233.1, manufacturer's recommendations, and/or local codes which are applicable. See the following requirements or refer to Diagram A for typical locations.
 - a. The exit termination of mechanical draft systems shall not be less than 7' above grade when located adjacent to public walkways.
 - b. A venting system shall terminate at least 3' above any forced air inlet located within 10'.
 - c. The venting system of other than a direct vent appliance shall terminate at least 4' below, 4' horizontally from, or 1' above any door, window, or gravity air inlet into the building.
 - d. The vent termination of a direct vent appliance with an input of 50,000 BTU/Hr or less, shall be located at least 9" from any opening through which vented gases could enter the building. With an input over 50,000 BTU/Hr, a 12" termination clearance shall be required.
 - e. The vent termination point shall not be installed closer than 3' from an inside corner of an L-shaped structure.
 - f. The vent termination should not be mounted directly above or within 3' horizontally from an oil tank vent or gas meter.
 - g. The bottom of the vent terminal shall be located at least 12" above finished grade.

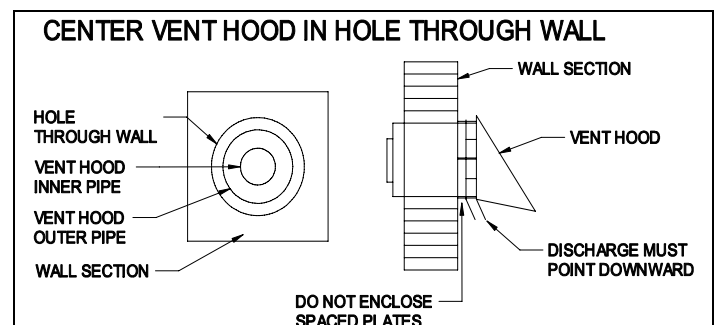

Figure 4

SIDE WALL VENT HOOD INSTALLATION

1. Use the inside wall plate as a template to mark the hole location. Cut a hole 1 inch larger than the marked hole to facilitate easy installation (See Figure 4)
2. Center vent hood through the hole from outside. Fasten the vent hood to the outside wall with the appropriate type of mounting screws.
3. Fasten the wall end plate to the inside wall with the appropriate type of mounting screws. **NOTE:** Apply sealant to the outside mounting plate of the vent hood to prevent leakage.
4. Connect the venter outlet or a properly sized section of vent pipe onto the inner pipe of the vent hood. Fasten the connection with three sheet metal screws or equivalent fastening method.
5. Seal the vent hood inlet connection and any other vent pipe joints on the outlet side of the venter with an approved high temperature silicone adhesive sealant or equivalent material.

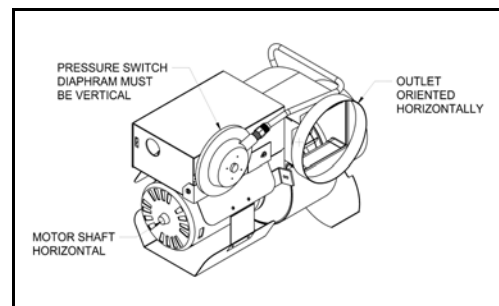

Figure 5

NOTE: Do not enclose the space between the plates on the outside of the vent hood or between the inner and outer pipe of the vent hood. This might

cause overheating of the wall structure. Local codes might require fencing around the vent hood outlet.

VENTER LOCATION

Install the power venter onto the vent hood inlet or as close to the vent hood inlet as possible. Always install the venter such that the motor shaft is horizontal and the pressure switch diaphragm is vertical (See Figure 5) When venting a draft induced gas fired heating appliance a barometric draft control must be installed on the vent system between the appliance outlet and the venter inlet. (See Figure 6)

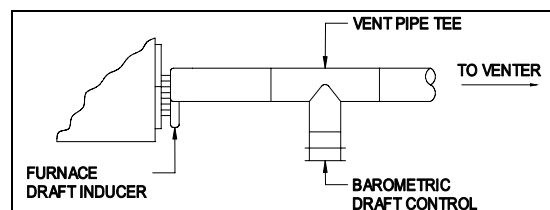

Figure 6

CAUTION: The power venter should never be installed with the motor shaft in the vertical position. This could allow heat to be trapped in the venter housing and radiate through the motor possibly causing motor deterioration and premature failure. Never attach the venter inlet directly to the outlet of the heating appliance. Also, a minimum of 6 inches clearance between the venter housing and combustible materials must be maintained.

CONNECTING VENTER TO THE FLUE PIPE

NOTE: The power venter should be supported in accordance with National Fuel Gas Code Z223.1, Section 7.910 as follows; A vent connector shall be supported for the design and weight of the material employed to maintain clearances and to prevent physical damage and separation of joints.

NOTE: For gas fired heating appliances not equipped with a draft hood, a barometric draft control must be installed between the heating appliance exhaust outlet and the power venter inlet to regulate any draft fluctuations during operation.

1. Use approved vent connectors to join the heating appliance outlet to the venter inlet securing each joint with sheet metal screws or equivalent means of fastening when required.
2. Seal all pipe joints on the outlet side of the venter with a high temperature silicone adhesive or equivalent. Test the vent connections for leaks by using a soap solution as recommended by the National Fuel Gas Code, A.N.S.I. Z223.1, Section 4.1.1.

OPTIONAL GSK-3 EXHAUST GAS SPILLAGE DETECTOR SWITCH INSTALLATION

NOTE: Installation of the GSK-3 secondary safety switch is recommended for LP and Natural gas fired appliances with a draft hood. This switch will detect exhaust gas spillage out of the draft hood due to a blocked vent system and/or inadequate draft during operation. When this switch senses spillage it interrupts the power supply to the gas valve which terminates the burner operation.

1. Mount the GSK-3 on the lower edge of the draft hood with the exposed thermal disk directed into the draft hood (See Figure 7)
2. Route the electrical wires along the heating appliance cabinet within an accepted wiring enclosure in accordance with the National Electrical Code and any applicable local codes. Keep the wires away from any HOT surfaces.
3. Wire the switch into the low voltage thermostat circuit. Refer to the appropriate wiring diagram in this manual.
4. After installation, check the amperage through the thermostat circuit and adjust the anticipator if necessary.

CAUTION: The GSK-3 is a manual reset switch. Investigate the system thoroughly for the cause of any shut down and correct the problem before resetting the GSK-3 and restarting the system.

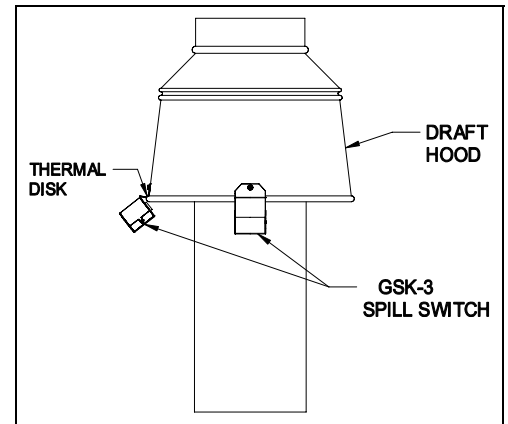

Figure 7

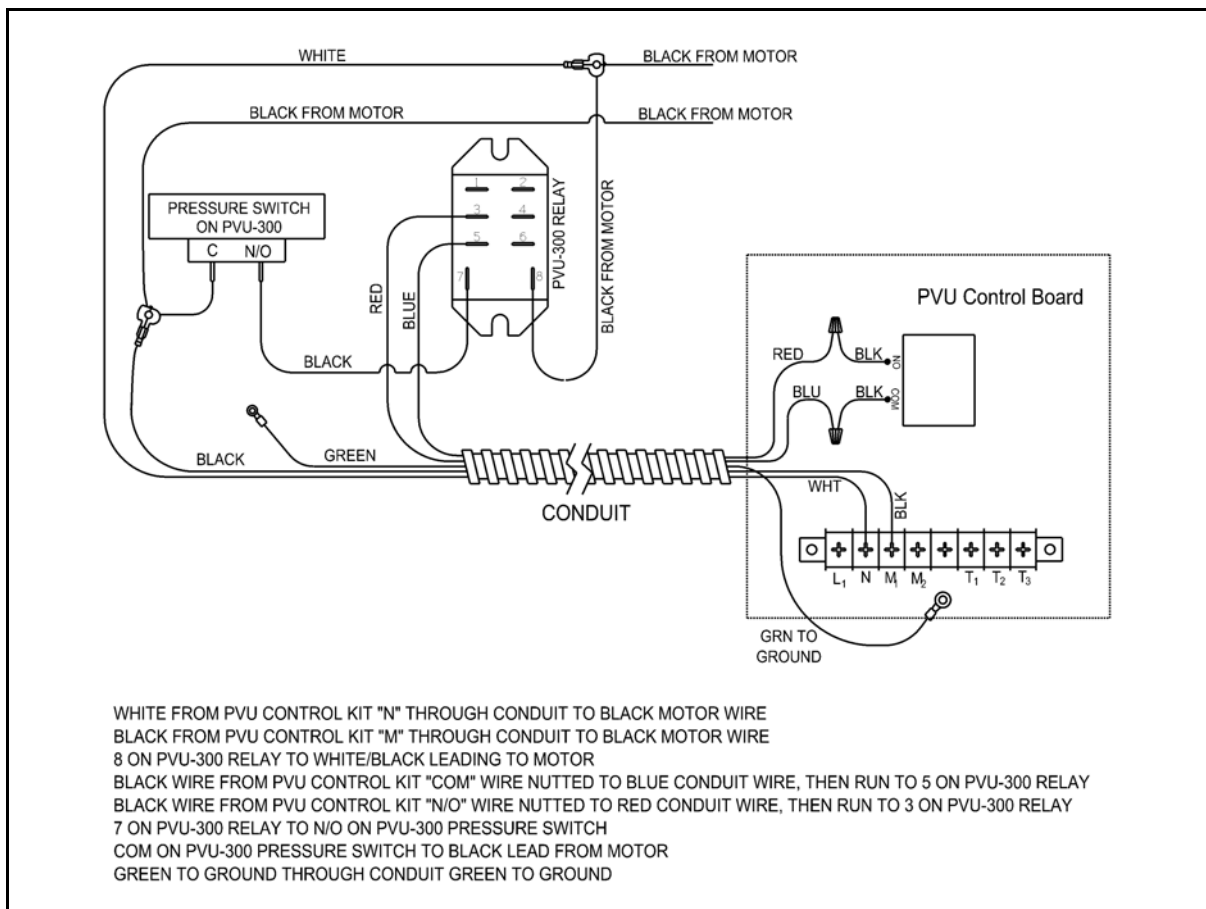

Diagram B – Internal Wiring Schematic for PVU-300

GENERAL WIRING INSTRUCTIONS

CAUTION: Disconnect electrical power before wiring power venter!

Connect line voltage (110/120 VAC) through junction box access hole labeled "120 VAC Only". Connect low voltage control wiring through junction box access hole labeled "24 VAC Control Wiring Only". VENTER MUST BE GROUNDED! Check ground circuit to make certain that venter has been properly grounded. The wiring must be protected by an over current protection circuit such as a fuse or circuit breaker rated at 15 amperes. Prevent wiring contact with any heat source.

IMPORTANT: The PVU-300 is shipped with the yellow mode wire connected to the 120VAC terminal. This is correct for 120VAC control (typical oil-fired). For 24VAC control (typical gas fired) the yellow mode wire must be disconnected from the 120VAC terminal and reconnected to the 24VAC terminal (see wiring diagrams).

NOTE: Wire the venter in accordance with the National Electrical Code and applicable local codes. Refer to Diagrams C and D for proper wiring specifications for a 24VAC Gas or 120VAC Oil fired appliance.

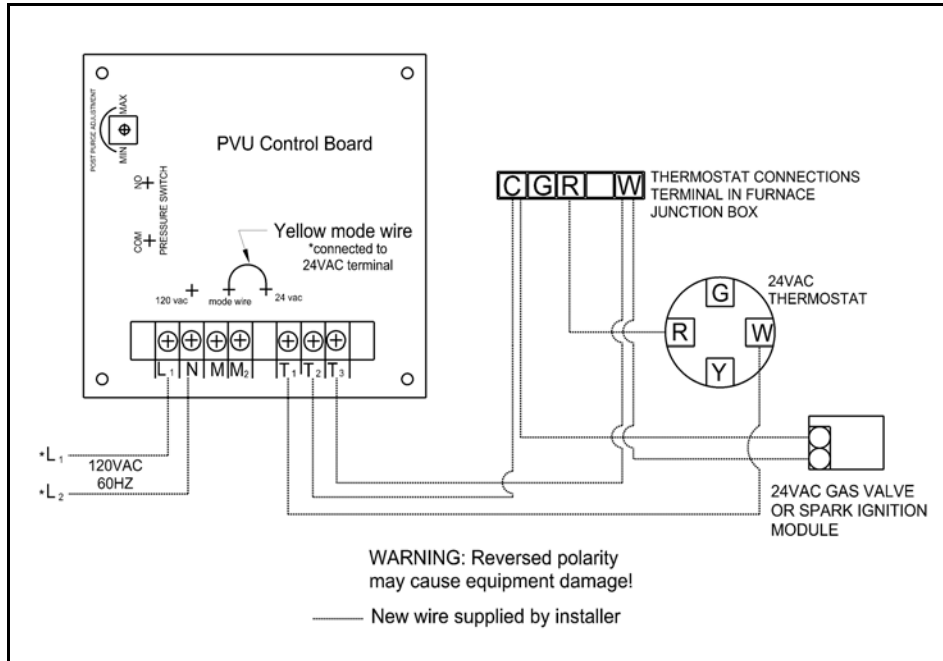

Diagram C – Wiring with 24 VAC Gas Valve

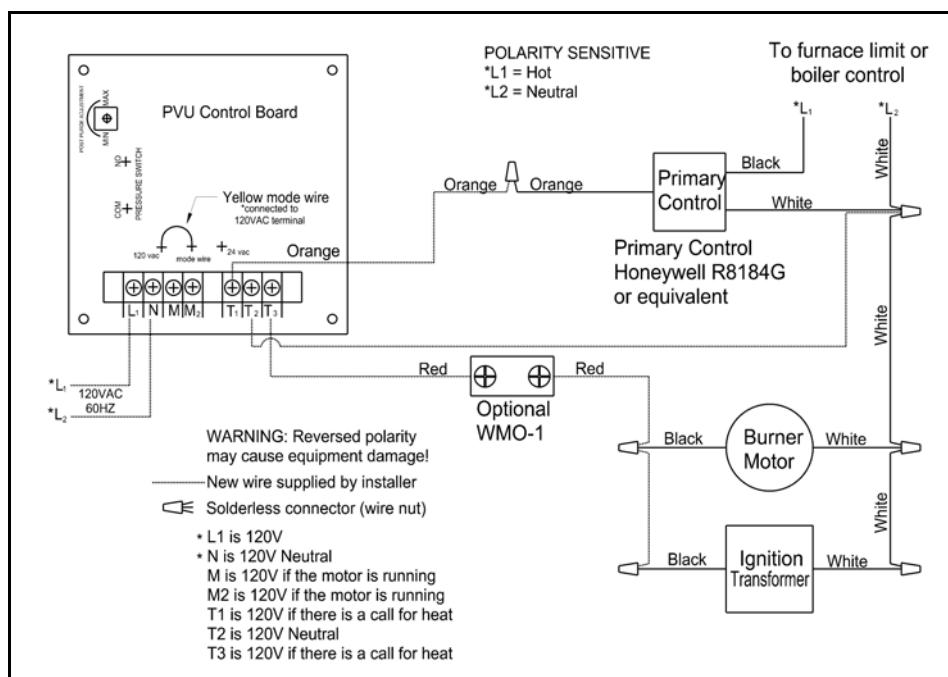

Diagram D – Wiring with a 120 VAC Oil Fired Primary Control

NOTE: A CK-20FV or CK-20FG control kit **MUST** be added to the system to properly control the venter with the operation of a 30mV water heater. Refer to Diagram E for proper wiring specifications.

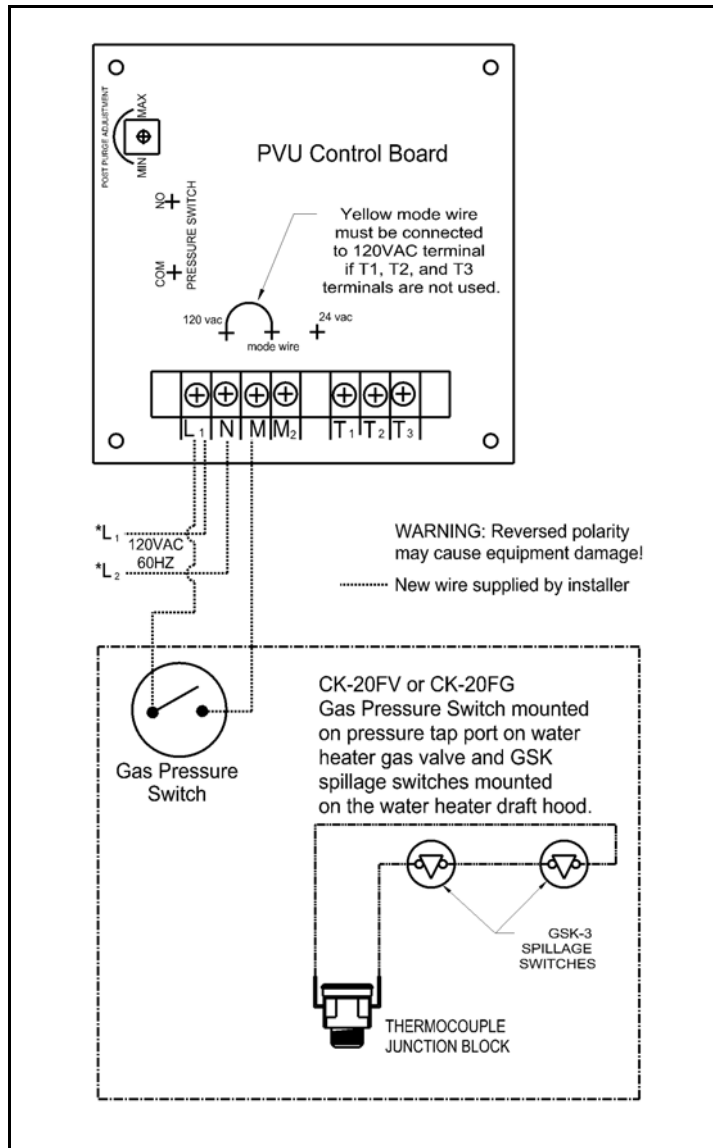

Diagram E – Wiring with a 30mV Water Heater

ADJUSTING THERMOSTAT ANTICIPATOR

If connecting the Power Venter system to a gas appliance with a thermostat anticipator, refer to the following to make adjustments. Disconnect one side of the thermostat circuit at the gas valve or burner control, and connect an ampere meter into the circuit. With the system running, take an amperage reading on the circuit. Check the nameplate or instructions for the thermostat to obtain the proper amperage level. Adjust amperage level by moving the anticipator lever. Reconnect the thermostat to the gas valve and start the system operating. Time the burn cycles and adjust as follows; To make the cycle time longer, increase the amount on the anticipator (**Example:** .45 to .5 Amps); to decrease cycle time, reduce the amount on the anticipator. (**Example:** .45 to .3 Amps) (See Figure 8)

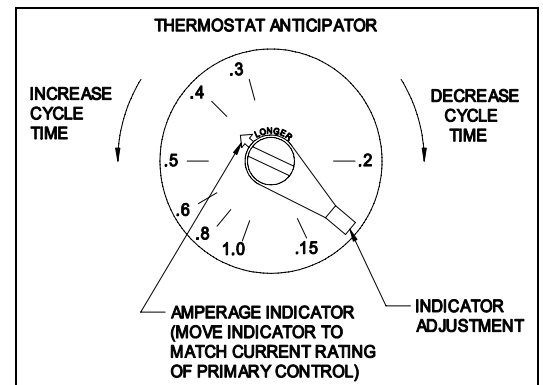

Figure 8

AIR FLOW ADJUSTMENTS

1. To properly adjust the venter air flow, loosen the inlet ring screws and open the choke plate approximately 1/2 to 3/4 open. (See Figure 9) Start the heating appliance following the manufacturer specified procedure, and set the thermostat to call for heat.
2. After the system has operated for several minutes to stabilize the exhaust gas temperature, check for air flow at the draft hood or the heating appliance outlet using a velocity meter, draft meter, or match test procedure.
3. Adjust the venter choke plate inward or outward to obtain the minimum draft necessary to maintain venting. Then increase the draft slightly (Approximately 10% over minimum flow rate) to ensure proper venting during any variations in venter performance, such as wind load or house depressurization.
4. Secure the choke plate into position by tightening the screws on the inlet collar (See Figure 9)

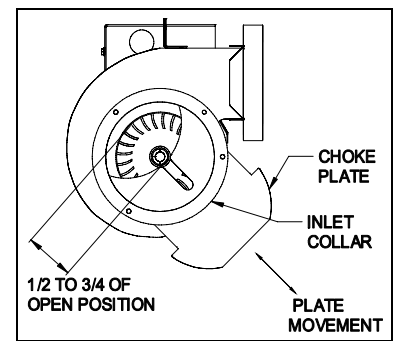

Figure 9

GENERAL INSTALLATION INSPECTION

Follow recommended procedures for safety inspection of a heating appliance in accordance with the National Fuel Gas Code A.N.S.I. Z223.1. The following procedure will help in evaluation of the venting system. It is intended as a guide to aid in determining that the appliance is properly installed and is in a safe condition for continuous use. This is a generalized procedure, which cannot anticipate all situations. Accordingly, in some cases deviation from this procedure may be necessary to determine safe operation of the equipment. If it is determined that a condition which could result in unsafe operation exists, the appliance should be shut off and the owner advised of the unsafe conditions. Corrections must be made prior to allowing continuous operation. The following steps should be taken in making a safety inspection.

1. Visually inspect the venting system for proper size and determine that there is no blockage, restriction, leakage, corrosion, or other deficiencies, which could cause unsafe operation.
2. To the extent possible, close all building doors, windows, and all doors to the room in which the heating appliance is located. Turn on clothes dryers and any exhaust fans so that they operate at maximum speed. Do not operate a summer exhaust fan. Also close all fireplace dampers. If after completing steps 3 through 7 it is believed that sufficient combustion air is not available, refer to the National Fuel Gas Code A.N.S.I. Z223.1 or any local codes for proper guidelines.
3. Place the appliance being inspected into operation. Follow the lighting instructions and adjust the thermostat so that the heating appliance will operate continuously.
4. Determine that the burner is operating properly and that the main burner ignition functions satisfactorily, by interrupting the electrical power of the appliance in any safely convenient manner. Test the burner safety device to determine if it is operating properly by extinguishing the pilot or disconnecting the flame safety circuit.
5. Visually determine that the main burner is burning properly, i.e. no floating, lifting, or flashbacks. Adjust the primary air shutter as required by the appliance manufacturer. If the appliance is equipped with high and low flame control or flame modulation, check for proper main burner operation at both flame levels.
6. Test for exhaust gas spillage at the draft hood or the barometric draft control after approximately 5 minutes of main burner operation. Use a draft meter or flame or smoke from match, candle or cigarette.
7. Turn on all fuel burning appliances within the same room so that they operate at their maximum capacity. Then repeat Steps 5 and 6.
8. Return all doors, windows, exhaust fans, fireplace dampers, and any other fuel burning appliances to their previous condition.

SYSTEM CONTROL CHECK PROCEDURES

1. Adjust the thermostat to call for heat and observe the power venting system for proper operation sequence. Repeat as necessary.
 - a. Thermostat calls for heat.
 - b. Venter relay is energized which starts venter motor.
 - c. Pressure switch closes which allows burner to fire.
 - d. Thermostat is satisfied, burner stops operation.
 - e. Venter continues to operate for up to 2 minutes during the post purge cycle.
2. While the system is in operation, disconnect the draft tube from the air pressure switch. The pressure switch should open and interrupt burner operation. Re-connect the draft tube to the air pressure switch, which should allow the burner re-light.
3. If a GSK-3 secondary safety switch is installed, allow the vent pipe to cool and disconnect the vent pipe between the appliance outlet and venter inlet. Block the vent connected to the appliance with a non-combustible material. Activate the heating system main burner and verify that the GSK-3 shuts down the burner within a few minutes or less. Reset the GSK-3 and repeat.

TROUBLESHOOTING TIPS

1. Burner does not fire when thermostat calls for heat.
 - a. Make sure draft tube is securely fastened to the air pressure switch, and is not blocked.
 - b. Check for continuity across pressure switch terminals when venter is operating.
 - c. Check wiring connections between air pressure switch, appliance, relay, yellow mode wire connection and PVU control board.
 - d. Relay should "click" when pressure switch closes.
2. Venter does not activate when thermostat calls for heat.
 - a. Check to see if relay closes when thermostat calls for heat.
 - b. Check wiring connections, including yellow mode wire connection.
 - c. Check motor for unrestricted shaft rotation.
3. Exhaust gas odor.
 - a. Check system draft level during operation.
 - b. Check vent system on outlet side of venter for leakage.
 - c. Check for negative pressure in building.

MAINTENANCE

1. **Motor:** Inspect the motor once a year - motor should rotate freely. The PVU's motor has sealed ball bearings, therefore, should not need oiling.
2. **Blower Wheel:** Inspect the blower wheel annually to clear any soot, ash or coating, which inhibits either rotation or airflow. Remove all foreign materials before operating.
3. **Vent System:** Inspect all vent connections annually for looseness, for evidence of corrosion and for flue gas leakage. Replace, seal, or tighten pipe connections if necessary. Check the power venter choke plate to insure it is secured in place. Check the barometric draft control, if installed, to insure the gate swings freely.
4. **System Safety Devices:** With the heating system operating disconnect the pressure sensing tube from the pressure switch on the venter. This should stop the burner operation. Re-connecting the tube will relight the burner. For 30 millivolt operating systems, disconnect one lead of the spill switch circuit from the thermocouple junction block. This should shut off the pilot and the burner. Re-connection will allow re-lighting of the pilot.

REPLACEMENT PARTS LIST

The following items are available for replacement, if necessary.

REPLACEMENT PARTS LIST	
DESCRIPTION	PVU-300
Motor	46512900
Blower Wheel	46513100
24 VAC Relay	46257300
Pressure Switch	46513200
CK-63/PVU Circuit Board	46399200

MULTIPLE VENTING SYSTEMS

1. To vent a 24 VAC controlled boiler or furnace and a 30 millivolt residential water heater using one PVU power venter refer to the following.
 - a. Follow the instructions for safe and proper venting previously specified in this manual. Make sure that the combined gross BTU/Hr input and equivalent vent pipe length does not exceed the maximum venting capacity of the venter selected.
 - b. A CK-20FV or CK-20FG control kit **MUST** be added to the system to properly control the venter during operation of the water heater. Refer to Figure 10 and Diagram F for vent pipe arrangement and wiring information.

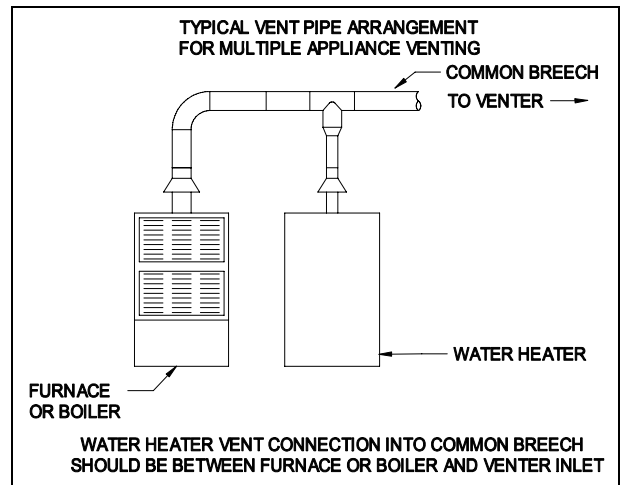

Figure 10

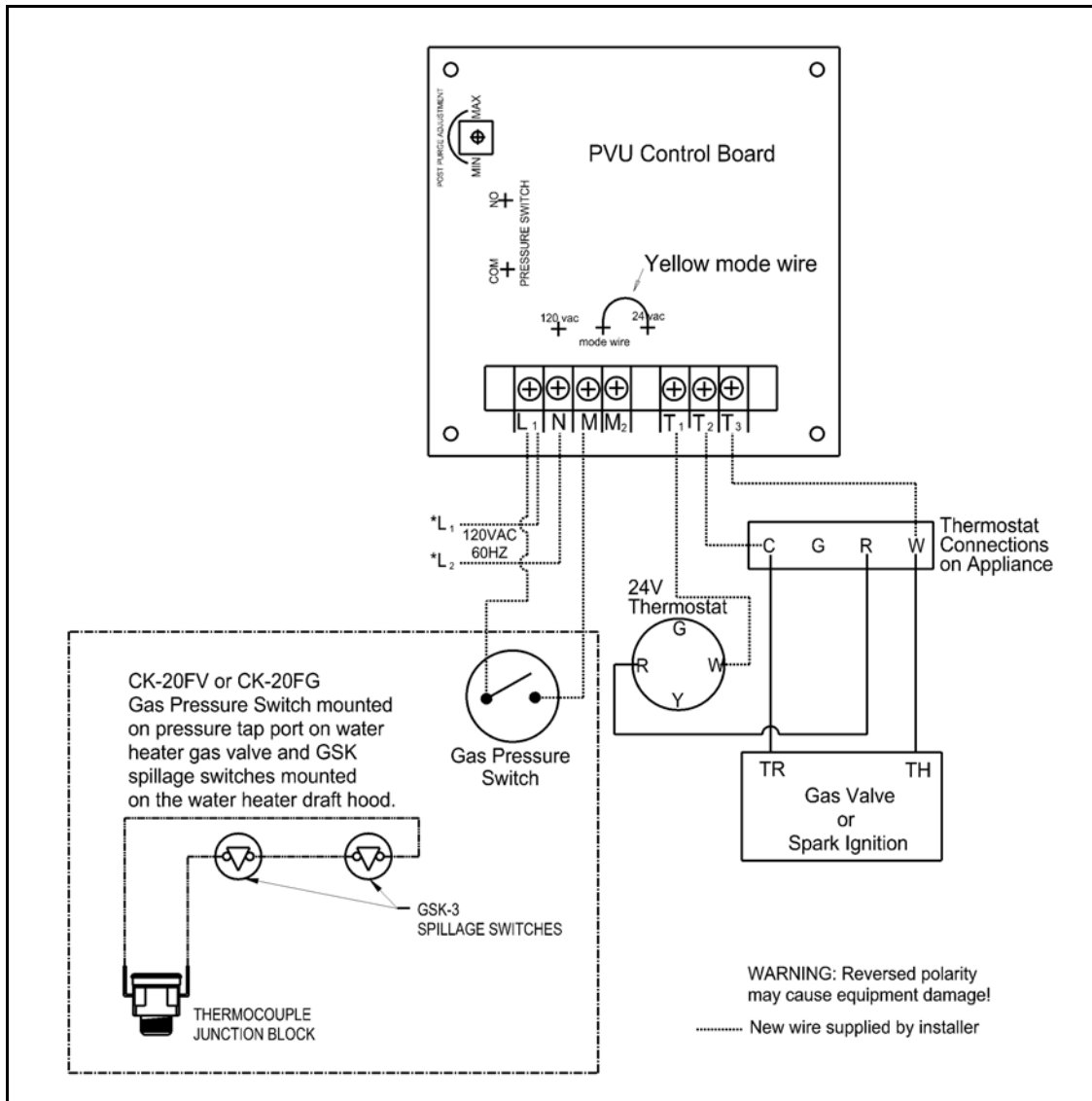

Diagram F – Multiple Wiring with 24 VAC Furnace and 30mV Water Heater

2. To vent two 24 VAC appliances using one PVU power venter refer to the following.
 - a. Follow the instructions for safe and proper venting previously specified in this manual. Make sure that the combined gross BTU/Hr input and equivalent vent pipe length does not exceed the maximum venting capacity of the venter selected.
 - b. A CK-41 Control Kit must be added to the system to properly control the venter when common venting an additional 24 VAC furnace or boiler. Tee the draft tube on the PVU unit to connect to the air pressure switch on the Control Kit. Refer to Diagram G for wiring instructions.

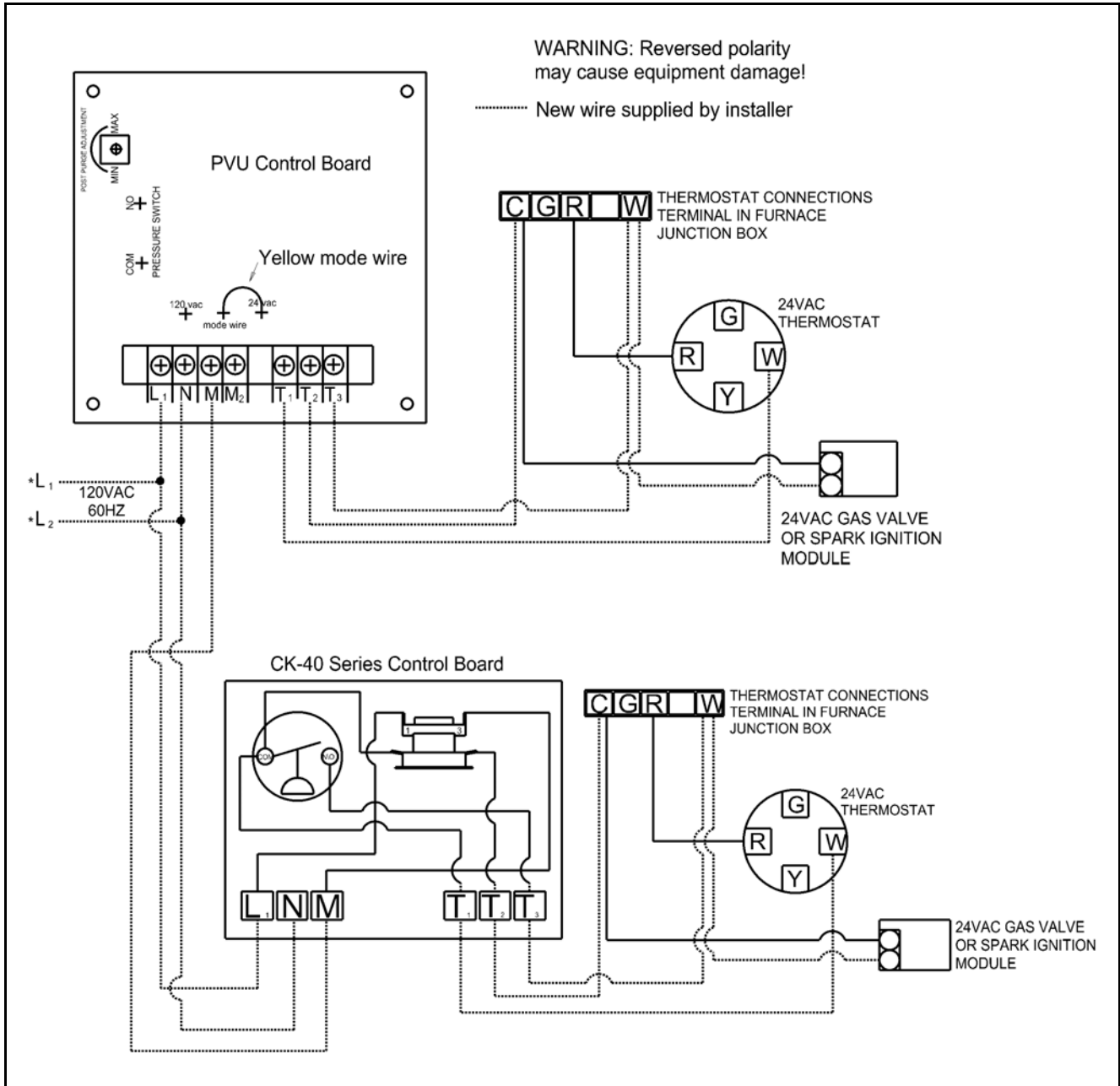
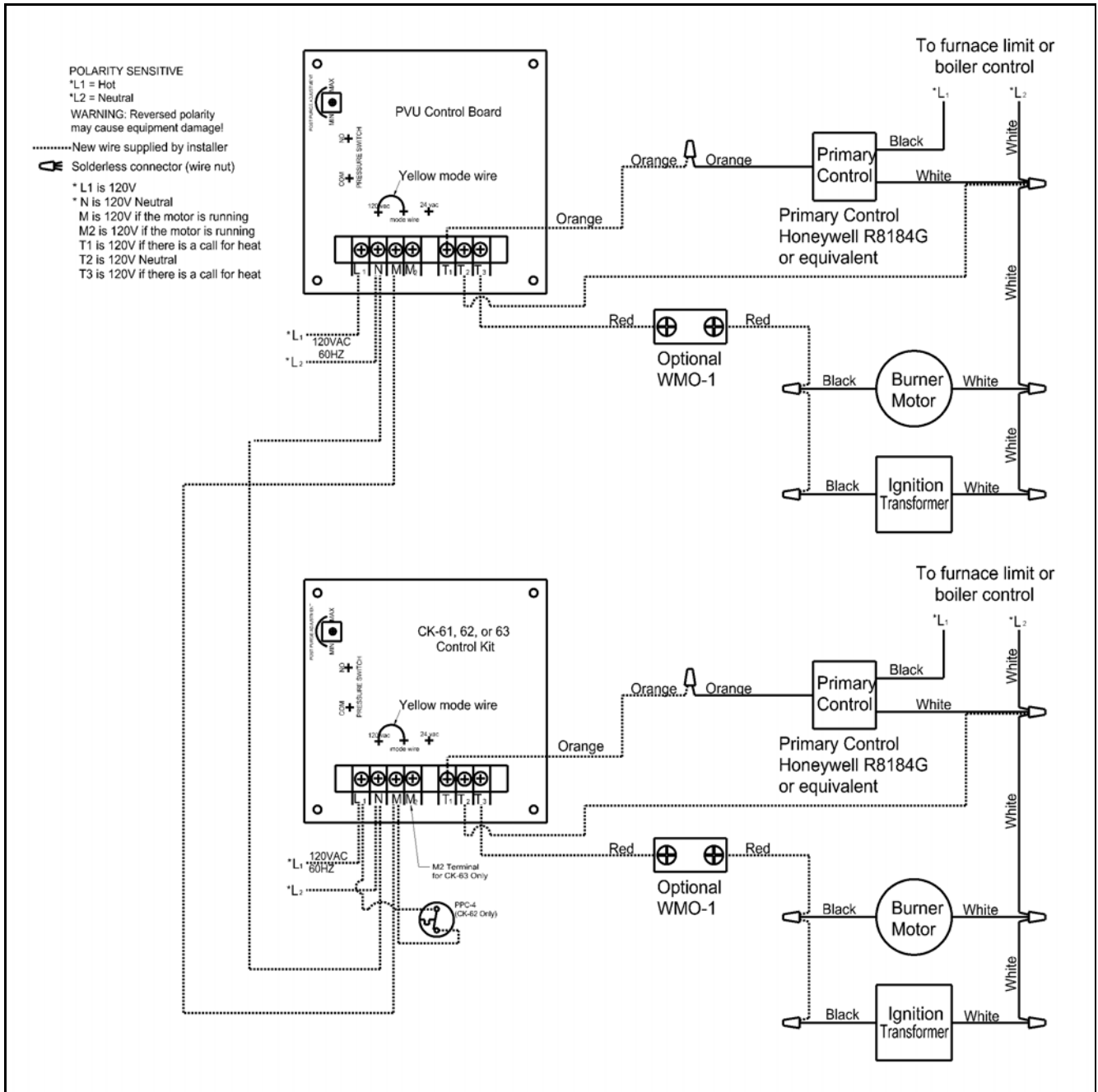

Diagram G – Multiple Wiring with two 24 VAC Appliances

3. To vent two 120 VAC appliances using one PVU power venter refer to the following.
 - c. Follow the instructions for safe and proper venting previously specified in this manual. Make sure that the combined gross BTU/Hr input and equivalent vent pipe length does not exceed the maximum venting capacity of the venter selected.
 - d. A CK-61, 62, or 63 Control Kit must be added to the system to properly control the venter when common venting an additional 120 VAC furnace or boiler. Tee the draft tube on the PVU unit to connect to the air pressure switch on the Control Kit. Refer to Diagram H for wiring instructions.



PV SERIES POWER VENTER: VERTICAL VENTING OPTION

Natural gas, lp gas or #2 fuel oil appliance rated at 75% or greater non-condensing type of appliance.
Maximum input temperature at power venter: 575°f

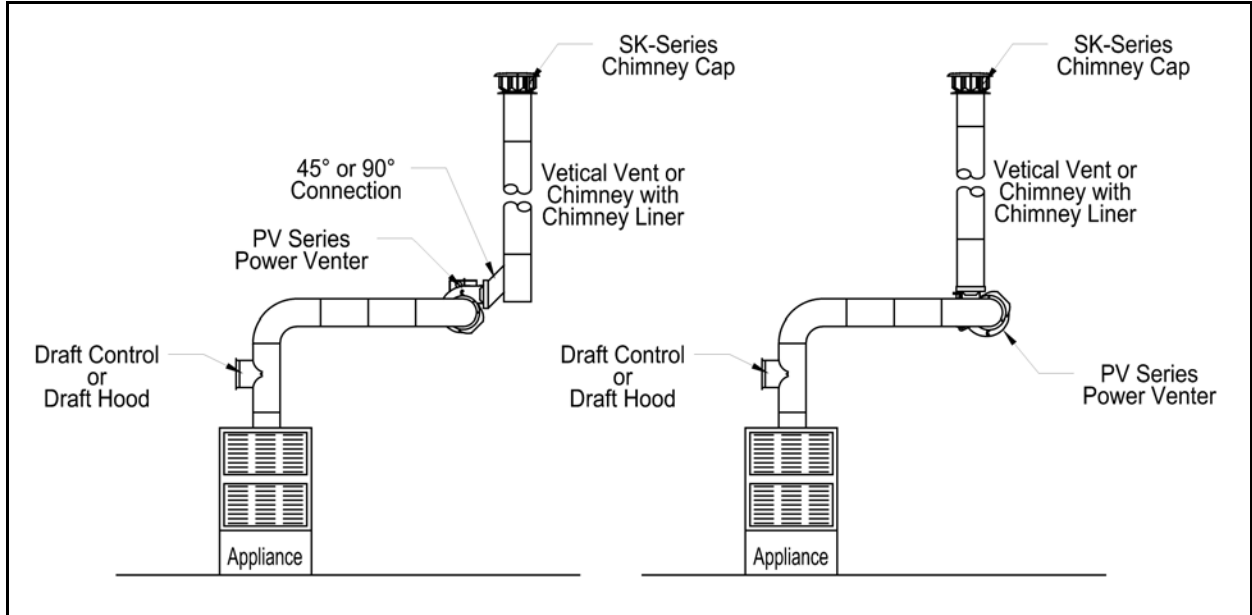

Diagram I – Vertical Venting Option

VENTING SYSTEM OPERATIONAL INFORMATION

Date:								
Heating appliance BTU/Hr input								
Gas valve operation pressure								
Vent system draft above draft hood or below barometric draft control								
CO ₂ measurement								
CO measurement								
Appliance outlet flue gas temperature								

INSTALLATION INFORMATION

MODEL NO.: _____ PVU-300 _____

INSTALLER'S NAME: _____

INSTALLER'S COMPANY: _____

INSTALLER'S PHONE NO.: _____

DATE OF INSTALLATION: _____



FIELD CONTROLS

The Venting Solutions Company™